

# SwitchPilot 3 Servo

## Instruction manual

2. Edition, May 2021

From Decoder Firmware 3.0.9

51832 SwitchPilot 3 Servo

SWITCH PILOT



<b>1. Declaration of conformity</b> .....	<b>3</b>
<b>2. WEEE-Declaration</b> .....	<b>4</b>
<b>3. Important Notes</b> .....	<b>4</b>
<b>4. Features</b> .....	<b>5</b>
4.1. General Features.....	5
4.2. Technical Data.....	5
4.3. Scope of delivery.....	5
4.4. Operating modes.....	6
4.4.1. Digital mode.....	6
4.4.2. Proportional mode .....	6
4.5. Servo types .....	8
4.5.1. Analog servos.....	8
4.5.2. Digital servos .....	8
4.5.3. ESU servo drive .....	8
<b>5. Connection to the digital system</b> .....	<b>9</b>
5.1. Terminals .....	9
5.2. Power supply by the digital system.....	10
5.3. External power supply .....	10
5.4. Wiring the outputs .....	11
5.4.1. Servo connection .....	11
5.5. Connecting the SwitchPilot Extension .....	12
5.5.1. Relay outputs.....	12
5.5.2. Turnout frog polarization .....	13
<b>6. Configuration with OLED</b> .....	<b>14</b>
6.1. Relationship accessory addresses / turnout numbers ..	14
6.1.1. Assigning turnout numbers.....	15
6.2. Introduction to the operating structure .....	16
6.3. Address mode for ROCO® command stations .....	17
6.4. Configuring outputs .....	17
6.4.1. Servo position and mode.....	17
6.4.2. Servo speed and relay response time.....	18
6.4.3. Servo seesaw effect (“Bouncing”).....	18
6.5. Servo pulse configuration.....	18
6.6. Function Mapping.....	19

6.7. Status information .....	20
6.7.1. Display software version & track voltage .....	20
6.7.2. Displaying the status of the outputs.....	20
<b>7. Configuration with LokProgrammer</b> .....	<b>21</b>
<b>8. Configuration POM</b> .....	<b>22</b>
8.1. Connection to the digital system.....	22
8.2. Reading and writing CVs with POM .....	22
<b>9. Configuration with the programming track</b> .....	<b>23</b>
9.1. Connection to the digital system.....	23
9.2. Read & Write CVs.....	23
<b>10. Learning turnout numbers from command station</b> ..	<b>23</b>
<b>11. RailCom®</b> .....	<b>24</b>
11.1. RailCom® Configuration .....	24
<b>12. Direct switching with the inputs for push buttons</b> ..	<b>24</b>
<b>13. Reset to factory default (decoder reset)</b> .....	<b>25</b>
13.1. With the programming button.....	25
13.2. With DCC systems.....	25
13.3. With the display.....	25
<b>14. Support</b> .....	<b>25</b>
<b>15. Menu references</b> .....	<b>26</b>
<b>16. Solenoid address &amp; turnout numbers</b> .....	<b>31</b>
<b>17. List of all supported CVs</b> .....	<b>33</b>
<b>18. Change history</b> .....	<b>38</b>
<b>19. Warranty certificate</b> .....	<b>39</b>

# Declaration of Conformity

## 1. Declaration of conformity

The manufacturer, ESU electronic solutions ulm GmbH & Co. KG, Edisonallee 29, D-89231 Neu-Ulm, hereby declares under its sole responsibility that the product

**Product name: SwitchPilot 3 Servo**

**Type: 51832**

complies with all relevant provisions of the Electromagnetic Compatibility Directive (2004/108/EC). The following harmonised standards have been applied:

EN 55014-1:2006 + A1:2009: Electromagnetic compatibility - Requirements for household appliances, power tools and similar electrical appliances - Part 1: Interference emission

EN 55014-2:1997 + A1:2001 + A2:2008: Electromagnetic compatibility - Requirements for household appliances, power tools and similar electrical appliances - Part 2: Immunity.

Copyright 1998 - 2021 by ESU electronic solutions ulm GmbH & Co KG. Irrtum, Änderungen die dem technischen Fortschritt dienen, Liefermöglichkeiten und alle sonstigen Rechte vorbehalten. Elektrische und mechanische Maßangaben sowie Abbildungen ohne Gewähr. Jede Haftung für Schäden und Folgeschäden durch nicht bestimmungsgemäßen Gebrauch, Nichtbeachtung dieser Anleitung, eigenmächtige Umbauten u. ä. ist ausgeschlossen. Nicht geeignet für Kinder unter 14 Jahren. Bei unsachgemäßem Gebrauch besteht Verletzungsgefahr.

Märklin® und mfx® sind eingetragene Warenzeichen der Firma Gebr. Märklin® und Cie. GmbH, Göppingen. RailCom® ist ein eingetragenes Warenzeichen der Firma Lenz® Elektronik GmbH, Gießen.

Alle anderen Warenzeichen sind Eigentum ihrer jeweiligen Rechteinhaber.

ESU electronic solutions ulm GmbH & Co. KG entwickelt entsprechend seiner Politik die Produkte ständig weiter. ESU behält sich deshalb das Recht vor, ohne vorherige Ankündigung an jedem der in der Dokumentation beschriebenen Produkte Änderungen und Verbesserungen vorzunehmen.

Vervielfältigungen und Reproduktionen dieser Dokumentation in jeglicher Form bedürfen der vorherigen schriftlichen Genehmigung durch ESU.

## 2. WEEE-Declaration

Disposal of old electrical and electronic equipment (valid in the European Union and other European countries with separate collection system).



This symbol on the product of the packaging or in the documentation means that this product must not be treated as household waste. Instead, this product is to be taken to the appropriate disposal point for recycling electrical and electronic equipment. If the product is disposed of correctly, you help to prevent negative environmental influences and damage to health that could be caused by improper disposal. Recycling material will preserve our natural resources. For more information about recycling this product, please contact your local citizens' office, household waste collection service or the store where you purchased this product.

## 3. Important Notes

Congratulations on your purchase of an ESU SwitchPilot 3 Servo decoder. This manual wants to introduce you step by step to the possibilities of the decoder. Therefore, a request:

Please carefully work through this manual prior to commissioning. Although all SwitchPilot decoders are very robust, a wrong connection could destroy the device. If in doubt, avoid „expensive“ experiments.



- The SwitchPilot is intended exclusively for use with electric model railway layouts. It may only be operated with the components described in this manual. Any use other than that described in this manual is not permitted.
- All connection work may only be carried out when the operating voltage is switched off.
- The power supply units must be protected in such a way that in the event of a short circuit, there is no risk of a cable fire. Use only commercially available model train transformers manufactured according to the VDE/EN standards, bearing the CE mark.
- Never operate the SwitchPilot unattended. The SwitchPilot is not a (children's) toy.
- Follow the principles of this manual when connecting the external components. The use of other circuits may cause damage to the decoder.
- The SwitchPilot is not waterproof: outdoor use is not intended and is done at your own risk.
- Do not attempt to open your SwitchPilot module. Improper treatment can destroy it.

## 4. Features

ESU SwitchPilot 3 Servo decoders are optimized for stationary use on your model train layout and were developed to control up to eight RC servo drives.

### 4.1. General Features

The SwitchPilot 3 Servo has eight outputs for controlling RC servo drives. He can control these drives so precisely that, in addition to switching points, any other slow movement can be controlled .

The SwitchPilot 3 Servo has built-in switch-on impulse suppression to eliminate or reduce the system-related „jerking“ of RC servos when the supply voltage is applied. Furthermore, the power supply to the servo can be interrupted to prevent some inexpensive servos from “humming”.

The SwitchPilot 3 Servo can receive its power directly from the digital system or an external DC or AC power supply.

SwitchPilot 3 Servo supports multi-protocol operation and can be used with central units supporting the Märklin® Motorola® system (e.g.: 6021, Central Station® or Mobile Station®) as well as DCC enabled command stations. Configuration can be carried out on the main (POM – Programming on the Main) and the programming track. Thanks to RailCom®, CVs can also be read out.



Operation with the Roco® Lokmaus 2 is not possible: The Lokmaus 2 sends only DCC locomotive commands instead of the required accessory commands.

As a special feature, the SwitchPilot 3 Servo can be used entirely without a digital center: if desired, up to 16 buttons can be connected for direct switching of the servos.

For simplifying the rather cumbersome configuration of accessory decoders, the SwitchPilot 3 Servo has an innovative operating concept consisting of a 4-line, illuminated OLED display and three input buttons. All settings can be checked directly on the decoder at any time with the help of the display and changed, if so desired. „Programming“ with the help of your command station is not required. It cannot get any easier.

## 4.2. Technical Data

	SwitchPilot 3 Servo
Input voltage	12V - 20V DC power supply 12V - 16V AC power supply Digital track voltage
Outputs	8 Servo outputs for RC servos Pulse lengths from 1.0ms to 2.0ms
Output power	Complete module 2A
Feedback inputs	Non existent.
Operating modes	DCC „Accessory Decoder“ with Rail-Com® (addressing according to RCN-213 or ROCO®). Turnout numbers 1 - 2048. Märklin® Motorola®. Turnout numbers 1 - 256. K83 and K84 operating modes. Direct triggering of the servos possible by using buttons.
Configuration	0.91“ OLED display with 3 buttons
Dimensions	86mm x 86mm x 25mm

### 4.3. Scope of delivery

The SwitchPilot 3 Servo comes with a removable terminal block (1x 4-pin for the track connection. Under part number 51800.SP.01 a pack of replacement terminal blocks is available from ESU.

# Operating modes

## 4.4. Operating modes

You may connect RC servos directly to any of the 8 outputs of the SwitchPilot 3 Servo. Contrary to geared motors, servo motors are intelligent actuators with integral intelligence that can self-reliantly move to the desired position and remain there. During this process they apply different power and angular frequency. If any resistance (force) is applied against the lever, then the servo will be regulated in order to always reach the pre-determined angle.

The required position is determined via an impulse wire (orange in case of Graupner® servos, otherwise white). A continuous power supply (4.8V – 6V) completes the interface. Every 20 – 25ms the servo expects to receive a positive impulse on the pulse wire with a duration of 1.0ms to 2.0ms. The duration of the impulse is directly proportional to the desired position. Fig. 1 illustrates the correlation.

There are servos of many different types and design sizes. They also differ in their gear reduction ratio and the adjustment travel. Thus, there are, for instance, servos for adjusting sails that make several turns.

There are many different types of servos on the market and not all of them are suitable for use with model trains.



Never try to move the turning lever manually! The gears of the servo may be damaged!

In general, there are two types of operating modes for servos. They can be individually set for each output.

### 4.4.1. Digital mode

In digital mode and subject to the settings of the control panel every servo can move to two end positions "A" and "B". With the SwitchPilot 3 Servo you can adjust both end positions as well as the speed at which the servo moves from "A" to "B".

In digital mode every servo will always stop at one of the two end positions "A" or "B", never in between.

As an option one can determine if the servo pulse should be continuously switched on or should only be active during movement. This is helpful when operating analogue servos. Furthermore, one can determine if the supply voltage should be turned off once the servo has reached the desired end position.



The digital mode is perfectly suitable for controlling turnouts or signals that should always remain in a fixed position.

### 4.4.2. Proportional mode

For the first time the proportional mode is instituted with the SwitchPilot 3 Servo and replaces the previously known positions "C" and "D" of servos.

In proportional mode the servo can move and stop at any position between the end position "A" and "B". The servo moves as long as the control panel transmits a command. Once you release the button, the servo stops. Thus, you can stop the servo at any desired position. The speed of movement is adjustable.



The proportional mode is ideally suited for applications like water standpipes for steam locomotives or gates of engine sheds. In fact, for any other application that requires in between positions.

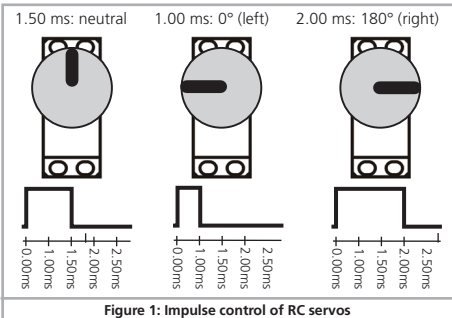

# Operating modes

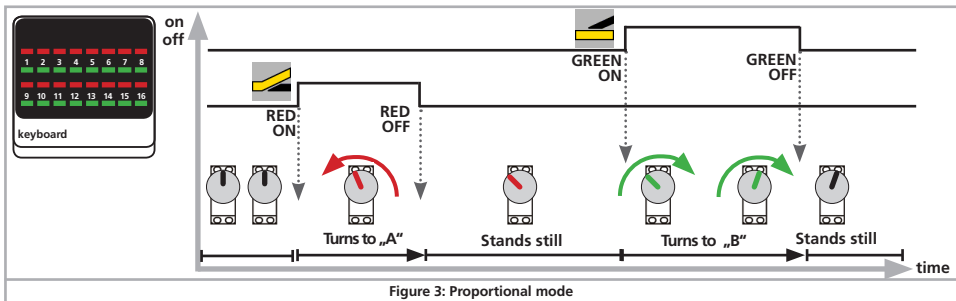
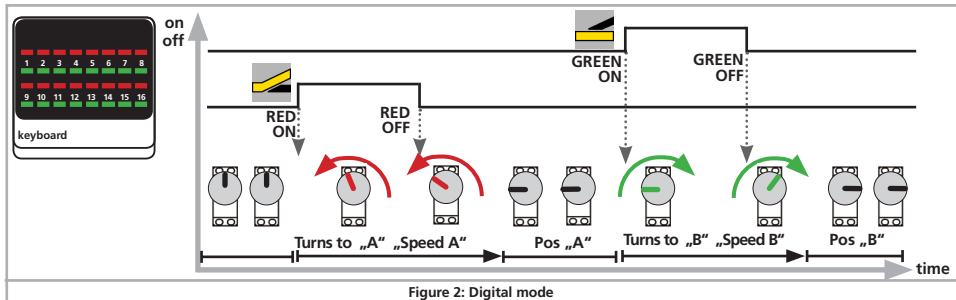

## 4.5. Servo types

Even if they look the same, technically different servos are available on the market. It is important that you configure the SwitchPilot 3 servo appropriately to avoid problems.

### 4.5.1. Analog servos

With a classic servo, the motor is only energized when a pulse signal is present. Without a signal, it follows the mechanical forces on the lever. If these servos „hum“ in the rest position, you can ensure silence by switching off the pulse. However, it is possible that the servos “twitch” when the pulse is switched on again.

For analog servos set the impulse configuration in CV 43 to 3.

### 4.5.2. Digital servos

With the digital servo, a microcontroller inside the servo ensures that the motor is readjusted even if there is no external impulse. These servos also tend to „hum“ when not in use, because the external actuating forces are through the motor should be compensated. A digital servo only comes to rest when the voltage is interrupted from the outside. The disadvantage of this method, however, is that the servo can twitch in an uncontrolled manner when the voltage is reapplied.

Set the impulse configuration CV 43 to 4 for digital servos.

### 4.5.3. ESU servo drive

With the servo drives (51804 with plastic gears, 51805 with metal gears), ESU offers particularly small drives that have been specially optimized for use in model railways. Both are equipped with a microcontroller whose special programming reliably prevents hum in the end position.

In addition, the drive is supplied with all the accessories necessary for the point control and saves you the hassle of searching for small parts.



# Connection to the digital system

## 5. Connection to the digital system

We recommend that you first configure the SwitchPilot 3 Servo decoder completely and then install it on the layout.

### 5.1. Terminals

Fig. 4 shows the SwitchPilot 3 Servo with all terminals.

- This pin header block is used to connect 8 RC servo drives (e.g. ESU, Futaba®, etc.) and forms the outputs 1-8 of the SwitchPilot 3 servo.
- The power supply of the SwitchPilot 3 including all connected loads is realized via the Terminals **Pw A** and **Pw B**. You can either use the track voltage or use an external power supply. We recommend an external power supply, particularly for larger layouts, because then the energy for powering the drives does not add to the load for the command station or booster.
- Connect the Terminals **Trk A** and **Trk B** to the track output of the command station (or booster) that controls the SwitchPilot 3 Servo.
- Input unit. The three buttons **PROG/OK** as well as (+) and (-) serve to configure the decoder, as explained in chapter 6.
- The display shows all settings of the decoder including turnout address and status of the outputs. After a few seconds, the screen saver displays the supply voltage.
- Extension socket for the SwitchPilot Extension relay module.
- These pin header blocks are used to connect 2 x 4 external switch buttons in order to be able to specify the servo positions directly without a digital center. Chapter 12 provides more information.

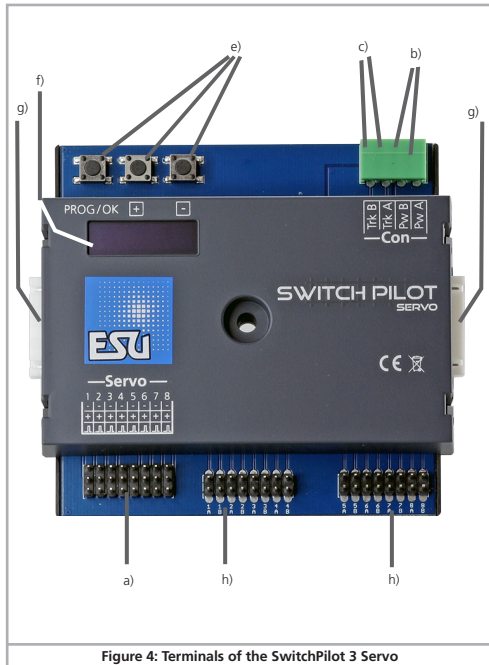

Figure 4: Terminals of the SwitchPilot 3 Servo

## 5.2. Power supply by the digital system

For smaller layouts with only a few electric loads turned on at the same time, the SwitchPilot 3 can be supplied directly from the command station or booster. The terminals Pw A and Pw B are connected parallel to the terminals Trk A and Trk B.



This wiring scheme must be used if you want to configure the SwitchPilot 3 Servo on the programming track of your command station. For more information, see Chapter 9.

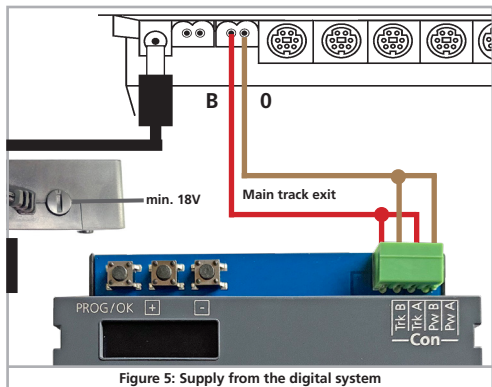

Figure 5: Supply from the digital system

## 5.3. External power supply

For larger layouts with many electric loads, we recommend the use of an external power supply. DC and AC power supplies are suitable with the specifications described in chapter 4.2. We recommend the use of a stabilized DC power supply with at least **14V DC** at least **3A** output power (e.g.: ESU part number 50119).



This type of wiring cannot be used for programming on the programming track. In this case, a temporary connection must be established as shown in chapter 5.2.

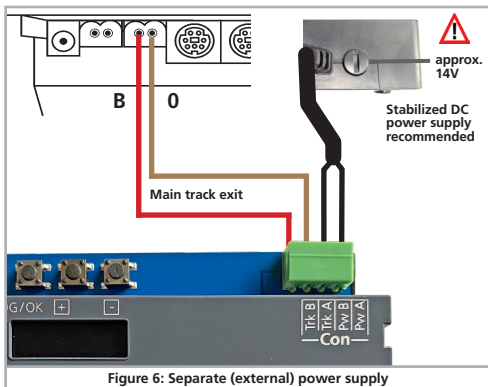

Figure 6: Separate (external) power supply

# Wiring the outputs

## 5.4. Wiring the outputs

### 5.4.1. Servo connection

All commercially available RC model building servos with a three-pole connection and positive pulse can be used. The SwitchPilot 3 Servo supplies them with 5V. Figure 7 shows the general connection.

Simply plug the connection cable of the servo into the corresponding socket on the SwitchPilot (servo). The pulse output is usually the white or orange wire.



Note the connection drawing on the housing of the SwitchPilot 3 Servo. An incorrect connection can destroy the servo or the SwitchPilot!

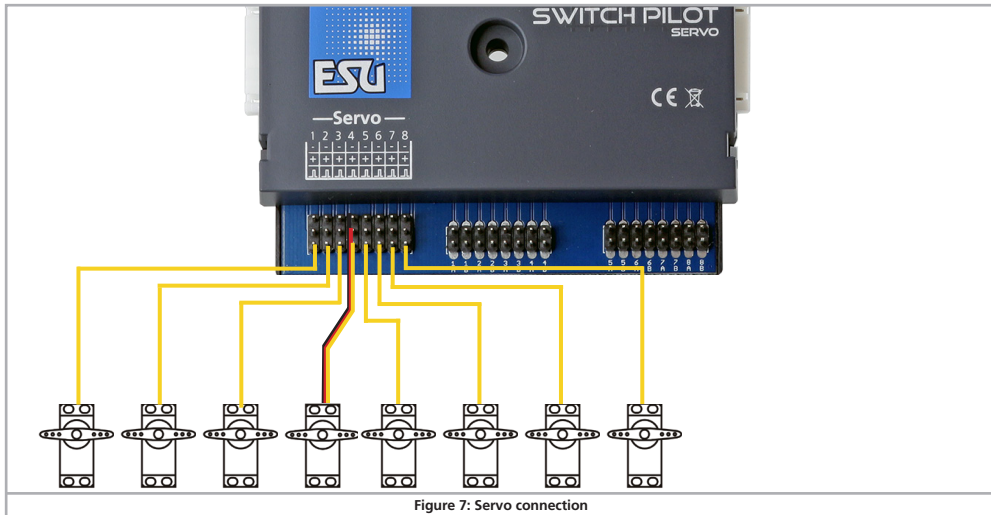

Figure 7: Servo connection

# Wiring the outputs

## 5.5. Connecting the SwitchPilot Extension

Up to two SwitchPilot Extension Modules can be docked to the side of the SwitchPilot 3 Servo. To do this, press the modules with the 8-pin plugs against each other until the latches on the plugs engage. The internal logic and the relay coils of the SwitchPilot extension module are also supplied by the SwitchPilot 3 servo.

The SwitchPilot Extension module on the left is responsible for outputs 1 to 4, the SwitchPilot Extension module on the right is responsible for outputs 5 to 8.

## 5.5.1. Relay outputs

Fig. 8 shows the connections:

- The outputs 1 to 4 are connected to relay outputs A and B, which are activated jointly (2x change-over contacts, bistable). Each relay output corresponds to the corresponding transistor output of the SwitchPilot 3. If the output **Out A** of the SwitchPilot 3 is active, the terminals **I** and **COM** of the relay output are also active. If the output **Out B** on the SwitchPilot 3 is active, terminals **II** and **COM** are also active.
- Terminals for ground and „U+“ (rectified track voltage, supplied by SwitchPilot 3) for powering DC turnout motors.

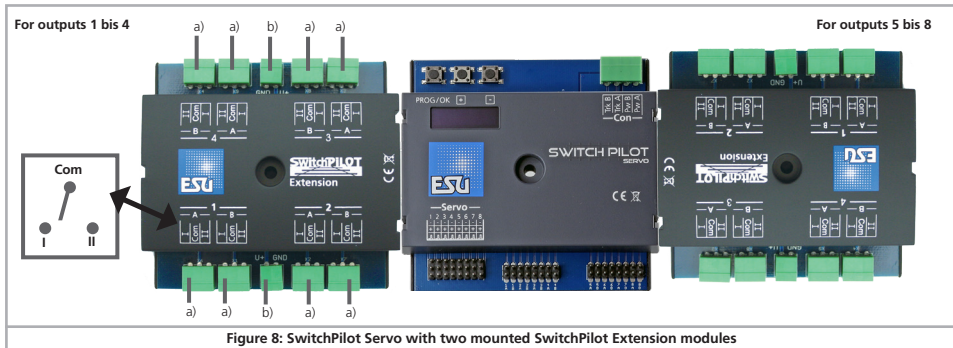
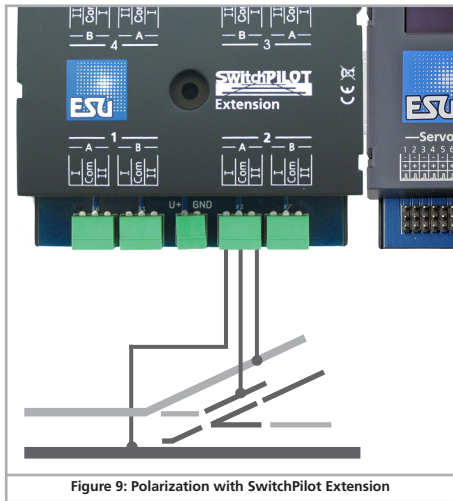

Figure 8: SwitchPilot Servo with two mounted SwitchPilot Extension modules

## 5.5.2. Turnout frog polarization

With the SwitchPilot Extension module, turnout frogs can be polarized very easily.



## 6. Configuration with OLED

The programming of accessory decoders was usually very cumbersome in the past. CV programming with the help of the hand-held throttle often failed due to the missing programming modes (e.g.: only very few command stations and/or throttles respectively central units support „POM for accessory decoders“) or forgotten addresses of decoders installed on the layout. Even assigning the decoder address presented many model railway enthusiasts with major obstacles. Reading the currently assigned decoder address is also quite cumbersome and causes a lot of displeasure.

To avoid such problems, the SwitchPilot 3 Servo is the first accessory decoder on the market working with an innovative operating concept. It consists of an illuminated multi-line OLED display and a 3-button input unit. This allows programming all (!) settings of the SwitchPilot 3 Servo in plain text directly on the decoder, without the need of external programming devices or cumbersome CV programming. In addition, the display shows the currently assigned turnout numbers at any time and can even accurately display the supply voltage (respectively track voltage). A screen saver prevents the OLED display from burning in.

### 6.1. Relationship between accessory addresses and turnout numbers

For addressing the outputs of the SwitchPilot 3 Servo decoder with the command station, so-called turnout numbers must be assigned to them. The number of turnout numbers is limited and depends on the digital system:

Motorola@: Turnout numbers 0001 to 0256

DCC: Turnout numbers 0001 to 2048  
(ROCO command stations 0001 to 2040).

The turnout numbers are arranged into four groups. The first group comprises turnout numbers 1,2,3,4, the second group the turnout numbers 5,6,7,8, the third group the turnout numbers 9,10,11,12, and so forth.

Each SwitchPilot 3 Servo can be assigned two 4-series group: this is the so-called accessory address.

The solenoid address 1 is stored internally in CV 1 and CV 9. The solenoid address 2 is stored internally in CV 35 and CV 36. The calculation of the turnout numbers from the values stored in the two CVs is regulated in the RCN-213.

The table in chapter 16 lists turnout numbers and corresponding accessory addresses. Only the first 256 turnouts are available when operating with Motorola® central units.



It is not possible to assign turnout numbers outside the group-of-4 limits to a SwitchPilot 3 Servo. For example, it would not be possible to assign turnout numbers 4, 5, 6 and 7, as these go beyond the limit of the accessory address groups. Please keep this in mind when assigning turnout numbers.

The two output groups 1 to 4 and 5 to 8 can be selected independently.



Due to a weakness in the DCC standard prior to the creation of the RCN-213, some command stations (especially ROCO® Multi-maus or Z21) calculate the turnout numbers differently. In this case please take note of chapter 6.3.

# Assigning turnout numbers

## 6.1.1. Assigning turnout numbers

The 8 servos of the SwitchPilot 3 Servo decoder react ex works to the turnout numbers 0001 to 0004 and 0005 to 0008. The turnout numbers can easily be changed directly on the SwitchPilot 3 Servo.

- a) Check whether the display shows the screen saver (lettering „SP“ and the supply voltage):

```
SPS»17.3V
```

- b) In this case, press the „**PROG/OK**“ button only (!) briefly. Now the SwitchPilot 3 Servo should display its current turnout numbers directly in plain text:

```
ADDRESS  
Swi tch 1-4: 0001-0004  
Swi tch 5-8: 0005-0008
```

- c) Press the „**PROG/OK**“ button. The turnout numbers 1-4 should now flash (inverse).

```
ADDRESS  
Swi tch 1-4: 0001-0004  
Swi tch 5-8: 0005-0008
```

- d) Press the button (+) or (-) to select the desired turnout numbers for output 1 to 4. The currently selected turnout numbers are displayed flashing.

- e) Press the „**PROG/OK**“ button again to confirm the turnout numbers for outputs 1 to 4. The display no longer flashes, but the one for outputs 5 to 8.

```
ADDRESS  
Swi tch 1-4: 0009-0012  
Swi tch 5-8: 0005-0008
```

- f) Press the button (+) or (-) to select the desired turnout numbers for output 5 to 8. The currently selected turnout numbers are displayed flashing.
- g) Press the „**PROG/OK**“ button again to confirm the turnout numbers for outputs 5 to 8. The display no longer flashes.

```
ADDRESS  
Swi tch 1-4: 0009-0012  
Swi tch 5-8: 0013-0016
```

Finished! Without programming or cumbersome handling on the handheld throttle or command station.

## 6.2. Introduction to the operating structure

The configuration with the aid of the OLED display and the 3-button input unit enables you to set all parameters of the SwitchPilot 3 Servo decoder.

All properties are arranged in so-called „panels“. A panel fills in all four lines of the display. The first line displays the name of the panel, and rows two to four display a maximum of three different setting options. With the help of the „+“ and „-“ buttons you can scroll between the individual panels.

- a) Name of the panel
- b) Name of setting option 1
- c) Value of the setting option 1
- d) Name of setting option 2
- e) Value of the setting option 2
- f) Name of the setting option 3
- g) Value of the setting option 3

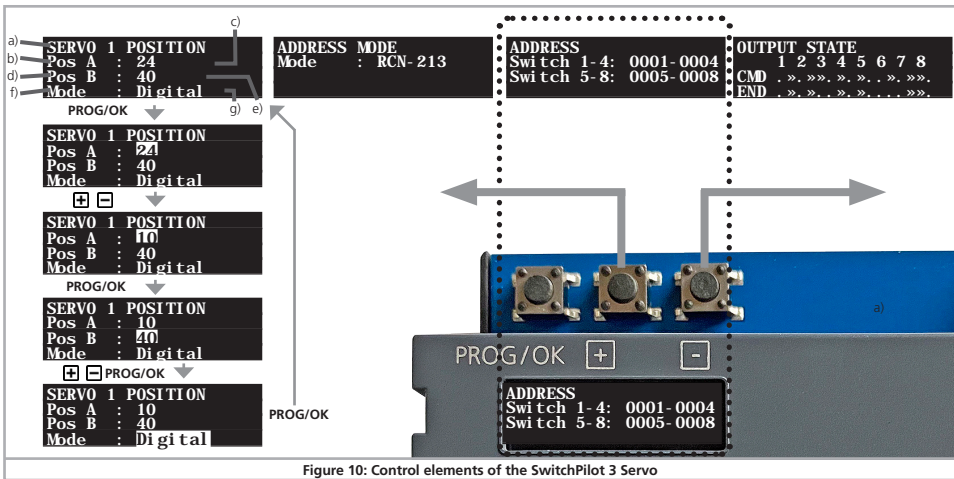



# Configuring outputs

- If you want to change a setting option of the currently selected panel, press the **PROG/OK** button once. The setting option 1 of the screen will now flash as a sign that it can be changed.
- For changing the respective setting use the (+) and (-) buttons. Press the button until the display shows the desired value. The decoder immediately applies the changes so you can see immediately what is happening.
- Confirm your entry with **PROG/OK**. After that, the next setting option will flash as a sign that it can now be changed.



If you do not want to change a setting option, but only want to proceed to the next one, just press the **PROG/OK** button. Then the current value is not changed.

- After you have changed the last of the three setting options respectively confirmed them by pressing **PROG/OK**, nothing will flash. You are now back in the display mode of the panel and can now either make changes to other setting options of the panel by pressing **PROG/OK** again or select another panel with the (+) and (-) buttons.

For a list of all possible panels and their setting options, see Chapter 15.

## 6.3. Address mode for ROCO® command stations

As already mentioned in Chapter 6.1, ROCO® command stations (specially the multiMaus, but also the Z21 in the standard setting) use a different computation method to calculate the turnout numbers from the accessory addresses. Set the decoder to “ROCO” to ensure that the SwitchPilot 3 handles instructions from ROCO® command stations correctly.

To do this, select „Mode” in the „ADDRESS MODE” panel, and then select the calculation method „ROCO”.

## 6.4. Configuring outputs

The properties of each output can be configured individually. Three panels are provided for each exit in order to be able to show the total of 9 options.

### 6.4.1. Servo position und mode

```
SERVO 1 POSITION
Pos A : 24
Pos B : 40
Mode : Digital
```

“Pos. A” defines the end position (the angle) of the servo in position “A”. The precise value depends on the type of servo and its mounting situation. This value can only be determined experimentally.



As soon as you change the value with (+) or (-), the servo connected to this output will move to the new value immediately. Thus, you may test the effect of any adjustment right away.

“Pos. B” defines the end position (the angle) of the servo in position “B”. The precise value depends on the type of servo and its mounting situation. This value can only be determined experimentally.



As soon as you change the value with (+) or (-), the servo connected to this output will move to the new value immediately. Thus, you may test the effect of any adjustment right away.

“Mode” enables you to set the desired mode:

- “Digital” configures the digital mode as per chapter 4.4.1
- “Proportional” configures the proportional mode as per chapter 4.4.2.

# Configuring outputs

## 6.4.2. Servo speed and relay response time

You may adjust the speed of movement for each output separately. Thus, prototypically slow movements can be realised.



Large values may possibly lead to such a slow speed that the mechanics of the servo may start to stall or move irregularly, thus causing the servo to fail in performing a smooth turn. In that case, please reduce the values or try to obtain another servo better suitable for extremely low speeds. Of course, the Switch Pilot 3 Servo cannot influence the mechanical properties of the servo.

```
SERVO 1 SPEED
Speed A : 40
Speed B : 40
SPE REL : Delay On
```

"Speed A" determines the duration of movement with which position "A" will be reached.



As soon as you change the value with (+) or (-), the servo connected to this output will continuously move between positions "A" and "B". This enables you to observe the effects of any value changes right away.

"Speed B" determines the duration of movement with which position "B" will be reached.

With option "SPE REL" one determines the point in time when the corresponding relay wired to the optionally connected SwitchPilot Extension module will be activated. Normally these relays switch immediately after receiving a control command. However, this may lead to a short circuit if the frog of a turnout is connected. This is due to the fact, that the points of the turnout are not moved immediately but are still connected to the stock rail for a moment.

One can adjust the response time for activating the relay once the servo has reached the centre position between the two end positions "A" and "B". The precise switching time depends on the desired regulating time of the servo.

Delay On      The relay is activated halfway through the movement between "A" and "B".  
Delay Off     The relay responds immediately.

## 6.4.3. Servo seesaw effect ("Bouncing")

If desired, every servo can facilitate a seesaw movement for simulating semaphore signals. One can choose at which end positions the effect should be triggered as well as how often and how strong this seesaw motion should be.

```
SERVO 1 BOUNCING
Bouncing: Pos A+B
Bounces : 0
Strength: 0
```

"Bouncing" determines if and where this effect should be activated:

Disabled	No bouncing effect (factory default).
Pos A	Bouncing after reaching position "A".
Pos B	Bouncing after reaching position "B".
Pos A + B	Bouncing after reaching either position.

Provided the bouncing function has been selected, you may adjust the following parameters:

"Bounces" determines the number of bouncing movements.  
"Strength" defines how far the servo should bounce back.

## 6.5. Servo pulse configuration

For avoiding any effects such as buzzing of analogue servos or jerking at switch-on of digital servos you may adjust the servo pulses of your SwitchPilot 3 Servo. The power supply for the servo may also be turned off if required.



To assure the correct functionality of your servos, it is paramount that all parameters are adjusted correctly. Buzzing servos may be overheated and could possibly be damaged or destroyed!

```
SERVO CONTROL
Imp On : Always
Imp Off: Never
PWR : Always
```

# Function mapping

There are three options for adjustment:

“Imp On” determines when a servo pulse shall be generated.

**Always** Once the power supply for the SwitchPilot 3 Servo is turned on, the servo impulse is generated immediately. Recommended for digital as well as ESU servos.

**On CMD** A servo impulse is only generated once a switching command has been transmitted to the servo. Recommended for analogue servos for avoiding buzzing after having reached the end position.

“Imp Off” determines the time after which the servo impulse will be switched off again.

**Never** After activating the servo impulse, it will be continually transmitted. Recommended for digital as well as ESU servos.

**Timeout** The servo impulse will be turned off about one second after reaching the end position (“A” or “B”). Recommended for analogue servos to avoid buzzing after reaching the end position.

“PWR” determines how the power supply for the servo is to be set up.

**Always** The power supply is never switched off. Recommended for analogue as well as ESU servos.

**On Move** The power supply is turned off once the servo has reached its end position. Recommended for digital servos for avoiding buzzing after reaching the end position.



Subject to design, construction and configuration of the servo other combinations of the above three options are feasible. If in doubt, simply try it out for reliably avoiding buzzing or jerking.



ESU recommends using ESU servos 51804, 51805 or 51806, whose special firmware do not permit any jerking or buzzing.

## 6.6. Function Mapping

Normally servos are controlled individually; occasionally it may be useful, to control two servos with one function button (e.g.: for level crossings). The SwitchPilot 3 Servo supports this functionality. One can assign the desired servo outputs that should be activated to any turnout number (1 – 8). There is a table listing every turnout number, consecutively numbered from F1 to F8.

```
FUNCTION MAPPING F1
Servo : » 1 2 3 4 5 6 7 8
          1 2 3 4 5 6 7 8
```

The table for turnout 1 (F1) shows which servo should be activated. Normally this would be servo 1. Let's assume you also want to activate servo 3, then proceed as follows:

- Press **PROG/OK** three times consecutively. With each press of the button the cursor moves one position to the right. Now the cursor should blink above number “3”.

```
FUNCTION MAPPING F1
Servo : » 1 2 3 4 5 6 7 8
          1 2 3 4 5 6 7 8
```

- Press button (+) for activating servo 3.
- Then press the **PROG/OK** button once more to confirm the entry. The cursor will then move on to servo 4.
- Press the **PROG/OK** button until the cursor disappears and nothing else is blinking.

# Status information

The display now shows that servos 1 and 3 will be switched with button F1 (turnout number 1).

```
FUNCTION MAPPING F1  
Servo : » . » . » . » . » .  
      : 1234 5678
```

Of course, the servo end positions as well as the speed can be adjusted individually for every servo, only the activation happens simultaneously.

 Whenever you work with Function Mapping, you should make sure that servos cannot be triggered by more than one turnout number, because there may be some unexpected results.

## 6.7. Status information

The SwitchPilot 3 Servo can display extensive status and diagnostic information, which can be particularly helpful, especially for wiring and troubleshooting.

### 6.7.1. Display software version & track voltage

The „Information“ panel displays both the hardware („HW“) as well as the software („SW“) version of the decoder. The supply voltage („Voltage“) of the outputs is also displayed.

```
INFORMATION  
HW : 3. 0  
FW : 3. 0. 9  
Voltage : 17. 3V
```

 If the SwitchPilot 3 Servo is powered directly by the command station, „Voltage“ displays the digital track voltage, otherwise the voltage of the connected power supply.

### 6.7.2. Displaying the status of the outputs

The „Output State“ table provides important information regarding the status of the outputs:

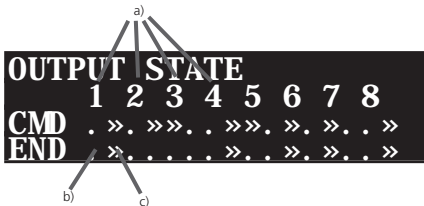

	1	2	3	4	5	6	7	8
<b>OUTPUT STATE</b>								
<b>CMD</b>	» .	» .	» .	» .	» .	» .	» .	» .
<b>END</b>	» .	» .	» .	» .	» .	» .	» .	» .

a) Number of servo output.

b) Servo has reached end position „A“.

c) Servo has reached end position „B“.

The row END indicates for each output from 1 to 8 if the servo has reached the desired end position „A“ or „B“.

While the servo is moving, there is no display. Non-existing bars indicate servos that are currently moving.

 In Proportional Mode there will be no bar on the display if the servo is somewhere between „A“ and „B“.

The row CMD indicates the most recent command for each output 1 to 8: A bar on the left (directly below the number) indicates that the command „Red“ is received from the command station. Similarly, a bar on the right indicates „Green“. Points are displayed until a valid command has been detected. The SwitchPilot 3 Servo records the most recent commands. Therefore the latest operating conditions will be restored after a power interruption.

## 7. Configuration with LokProgrammer

Please always use the latest PC software for your LokProgrammer, but at least version 5.1.0. To ensure a correct reading, connect the SwitchPilot 3 Servo as shown in Fig. 11 (**Pw A** and **Pw B**).

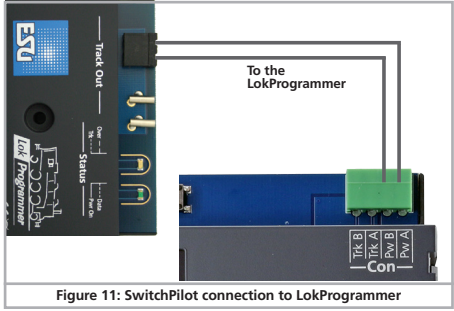

Figure 11: SwitchPilot connection to LokProgrammer

## 8. Configuration POM (Programming on the Main)

The SwitchPilot 3 Servo may remain installed on your layout during programming. For POM to work, your command station must also support „Programming on the Main (POM)“ for accessory decoders (1). Thanks to RailCom®, ECoS owners can even read out the values (see chapter 11)..

### 8.1. Connection to the digital system

The SwitchPilot 3 Servo does not require any special connections. It may remain wired as shown in chapter 5.2. respectively 5.3.

### 8.2. Reading and writing CVs with POM

Select “POM” as well as „Accessory decoder” on your command station. Make sure that the correct accessory address is selected.

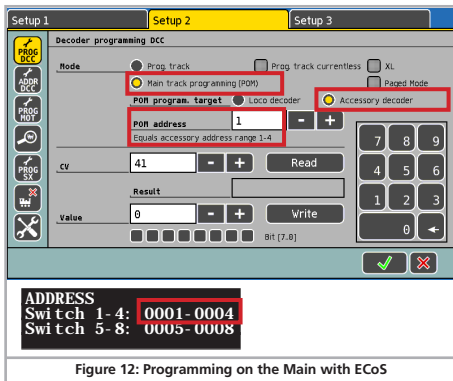

Figure 12: Programming on the Main with ECoS

You can write all the CVs of the SwitchPilot 3 Servo decoder and read them subject to the capabilities of the command station. With the ECoS, this is done as follows:

- Go to the main programming menu of the ECoS.
- Select “POM”, “DCC” and “Accessory decoder”.
- Select the „POM address” of the SwitchPilot 3. Alternately the corresponding turnout numbers are displayed as well.
- Select the CV you want to read or write.
- Press the „Read” or „Write” button.

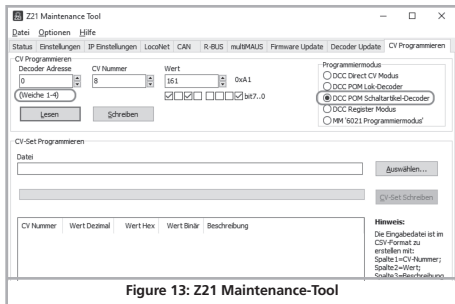

Figure 13: Z21 Maintenance-Tool

With the aid of Z21 maintenance tool, the ROCO® Z21 can also read or write the CV values of the SwitchPilot 3 Servo.

For this to work, RailCom® must be active on the SwitchPilot 3. Please also refer to chapter 11.



Unfortunately, many command stations do not support the POM mode for accessory decoders, but only for mobile (locomotive) decoders. In this case, configure the SwitchPilot directly using its display.

# Configuration with the programming tack

## 9. Configuration with the programming track

In some cases, it may be desirable to change the properties of the SwitchPilot via the programming track of the digital system. There, the CVs can not only be written, but also read. This is conveniently done before the final installation on the layout.

### 9.1. Connection to the digital system

Wire the SwitchPilot 3 Servo as described in chapter 5.2. Power must be provided by the digital system.

### 9.2. Read & Write CVs

Reading should work with all DCC compliant command stations. However, some command stations do not provide enough voltage for the programming track or sometimes report an overcurrent. In these cases, POM should be used, or - even better - configure the SwitchPilot directly using its the display..

## 10. Learning turnout numbers from command station

The accessory address (and thus the assigned turnout numbers) can also be learned directly from the command station. To do this, the SwitchPilot 3 Servo must first be put into ADDRESS mode:

- Press the **PROG/OK** button when the screen saver is displayed.
- Press the **PROG/OK** button, then the previous turnout numbers (factory default: 0001-0004) will flash inversely.

```
ADDRESS  
Switch 1- 4: 0001-0004  
Switch 5- 8: 0005- 0008
```

The decoder is now ready to „learn“ an address as soon as an accessory of the desired group of 4 is switched on at the command station.

- Now turn on an accessory of your choice at the command station. How accessories are switched, you can find out in the manual of your command station or the handheld throttle.

- Once the switch command has been understood by the SwitchPilot, the new address is saved and the numbers no longer flash. If you want to change the address of the second group, proceed as follows:
- Press the **PROG/OK** button, then the previous turnout numbers (factory default: 0001-0004) will flash inversely.
- Press the **PROG/OK** button again so that the turnout numbers for the second group (ex works 0005-0008) flash inversely.

```
ADDRESS  
Switch 1- 4: 0001-0004  
Switch 5- 8: 0005-0008
```

- Now turn on an accessory of your choice at the command station. How accessories are switched, you can find out in the manual of your command station or the handheld throttle.
- Once the switch command has been understood by the SwitchPilot, the new address is saved and the numbers no longer flash.

- i** The assignment of the turnout numbers is always carried out in ascending groups of 4. No matter what accessory you switch, the first output will always be aligned at the beginning of the group of 4.

#### Example 1:

You switch the turnout number 1. All four outputs are then configured in ascending order to turnout numbers 1 to 4.

#### Example 2:

You switch the turnout number 3. All four outputs are also configured in ascending order to turnout numbers 1 to 4, because turnout number 3 is in the same group of 4 as turnout number 1 from the first example.

#### Example 3:

You switch the turnout number 11. All four outputs will now receive the turnout numbers 9 to 12 in ascending order.

## 11. RailCom®

RailCom® is a technique for transferring information from the decoder back to the command station. When RailCom® is switched on, the CV values of the SwitchPilot can be read out directly on the main. From the factory, RailCom® is active on SwitchPilot 3 Servo.

### 11.1. RailCom® Configuration

If necessary, RailCom® can be disabled on the SwitchPilot.

```
RAILCOM
Mode   : Enabl ed
CH2    : Enabl ed
```

In this case „Mode“ must be set to „Disabled“. The value of CH2 is intended for future expansions and should not be changed.

## 12. Direct switching with the inputs for push buttons

The SwitchPilot 3 Servo is also suitable for switching the 8 servo outputs without a digital system. Therefore it may also be used by the “classical” analogue model train enthusiasts.

The SwitchPilot 3 Servo receives the info regarding the desired end positions via the 16 push buttons (8 servos with two end positions each). Wire the push buttons as shown in Fig. 14:

- The push buttons must be free of potential.
- A short impulse is sufficient for switching.

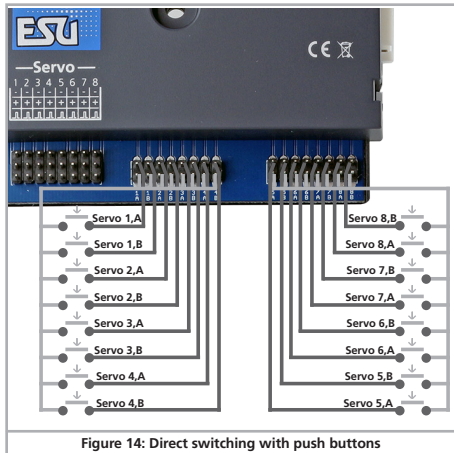

Figure 14: Direct switching with push buttons



# Decoder reset & support

## 13. Reset to factory default (decoder reset)

You can restore the decoder's factory default settings at any time.

### 13.1. With the programming button

- Disconnect the power supply to the SwitchPilot 3 decoder. The display must go out.
- Press and hold the PROG/OK button.
- Reconnect the power supply for the decoder. The decoder will be reset to factory default values.
- Release the PROG/OK button. The turnout numbers are now flashing because the SwitchPilot 3 expects to assign new turnout numbers (as described in chapter 6.1.).
- Confirm the turnout numbers with PROG/OK or first assign the new turnout numbers with (+) or (-).

### 13.2. With DCC systems

To do this, write the **value 8 in CV 8** either via POM (wiring as per chapter 8) or on the programming track (wiring as per chapter 9). The display of the SwitchPilot 3 briefly goes dark, after which the factory values are restored.



Writing in CV 8 is a special case, so some command stations may display an error „err02“ or similar. However, the SwitchPilot will accept the command.

### 13.3. With the display

The „RESET DECODER“ panel on the display enables you to restore the factory default values directly.

RESET DECODER  
Do Reset: **Yes**

- In the “Do Reset” option, select „Yes“ and confirm with **PROG/OK**. The display will flicker briefly, after which the SwitchPilot will be restored to have factory default values again.

## 14. Support

Should you have questions regarding your SwitchPilot to which you have not found the right answer in this manual please first contact your hobby shop. The people there are your competent contact for all questions relating to model trains. In difficult cases, you can contact us directly. Look first on our website under «Support / FAQ» to see whether the question has already been answered. If this is not the case, we ask you to make these available to us either in our support forum or to contact us by e-mail. We also provide a telephone hotline, which should only be used in the case of really special requests:

### For Germany

by phone: +49 (0) 731 - 1 84 78 - 106  
Tuesday & Wednesday  
from 10.00 to 12.00 o' clock  
by Fax : +49 (0) 731 - 1 84 78 - 299  
by E-Mail: [www.esu.eu/kontakt](http://www.esu.eu/kontakt)  
by mail: ESU GmbH & Co. KG  
Edisonallee 29  
D-89231 Neu-Ulm  
[www.esu.eu](http://www.esu.eu)

### For USA, Canada, Australia

by phone: +1 570-980-1982  
Tuesday & Thursday  
from 8am to 4pm (EST)  
by Fax : +1 866-591-6440  
by E-Mail: [support@loksound.com](mailto:support@loksound.com)  
by mail: ESU LLC  
1304 Jordan Ave  
Montoursville PA 17754  
[www.loksound.com](http://www.loksound.com)

# Menu references SwitchPilot 3 Servo

## 15. Menu references

No	Screen	Options
01	<b>ADDRESS</b> Switch 1-4: 0001-0004 Switch 5-8: 0005-0008	Switch 1-4: Turnout numbers Servo 1 to 4 Switch 5-8: Turnout numbers Servo 5 to 8
02	<b>ADDRESS MODE</b> Mode : RCN-213	Mode : RCN-213: Addressing as RCN-213. Mode : ROCO : Addressing as ROCO.
03	<b>SERVO 1 POSITION</b> Pos A : 24 Pos B : 40 Mode : Digital	Pos A : 0 .. 63: Servo 1 End position "A" Pos B : 0 .. 63: Servo 1 End position "B" Mode : Digital   Proportional
04	<b>SERVO 1 SPEED</b> Speed A : 40 Speed B : 40 SPE REL : Delay On	Speed A : 0 .. 63: Adjustment speed on the way to "A" Speed B : 0 .. 63: Adjustment speed on the way to "B" SPE REL : Delay On   Delay Off
05	<b>SERVO 1 BOUNCING</b> Bouncing: Pos A+B Bounces : 0 Strength: 0	Bouncing: Disabled   Pos A   Pos B   Pos A+B Bounces : 0 .. 31 Strength: 0 .. 31
06	<b>SERVO 2 POSITION</b> Pos A : 24 Pos B : 40 Mode : Digital	Pos A : 0 .. 63: Servo 2 End position "A" Pos B : 0 .. 63: Servo 2 End position "B" Mode : Digital   Proportional
07	<b>SERVO 2 SPEED</b> Speed A : 40 Speed B : 40 SPE REL : Delay On	Speed A : 0 .. 63: Adjustment speed on the way to "A" Speed B : 0 .. 63: Adjustment speed on the way to "B" SPE REL : Delay On   Delay Off
08	<b>SERVO 2 BOUNCING</b> Bouncing: Pos A+B Bounces : 0 Strength: 0	Bouncing: Disabled   Pos A   Pos B   Pos A+B Bounces : 0 .. 31 Strength: 0 .. 31

## Menu references SwitchPilot 3 Servo

No	Screen	Options
09	<b>SERVO 3 POSITION</b> Pos A : 24 Pos B : 40 Mode : Digital	Pos A : 0 .. 63: Servo 3 End position "A" Pos B : 0 .. 63: Servo 3 End position "B" Mode : Digital   Proportional
10	<b>SERVO 3 SPEED</b> Speed A : 40 Speed B : 40 SPE REL : Delay On	Speed A : 0 .. 63: Adjustment speed on the way to "A" Speed B : 0 .. 63: Adjustment speed on the way to "B" SPE REL : Delay On   Delay Off
11	<b>SERVO 3 BOUNCING</b> Bouncing: Pos A+B Bounces : 0 Strength: 0	Bouncing: Disabled   Pos A   Pos B   Pos A+B Bounces : 0 .. 31 Strength: 0 .. 31
12	<b>SERVO 4 POSITION</b> Pos A : 24 Pos B : 40 Mode : Digital	Pos A : 0 .. 63: Servo 4 End position "A" Pos B : 0 .. 63: Servo 4 End position "B" Mode : Digital   Proportional
13	<b>SERVO 4 SPEED</b> Speed A : 40 Speed B : 40 SPE REL : Delay On	Speed A : 0 .. 63: Adjustment speed on the way to "A" Speed B : 0 .. 63: Adjustment speed on the way to "B" SPE REL : Delay On   Delay Off
14	<b>SERVO 4 BOUNCING</b> Bouncing: Pos A+B Bounces : 0 Strength: 0	Bouncing: Disabled   Pos A   Pos B   Pos A+B Bounces : 0 .. 31 Strength: 0 .. 31
15	<b>SERVO 5 POSITION</b> Pos A : 24 Pos B : 40 Mode : Digital	Pos A : 0 .. 63: Servo 5 End position "A" Pos B : 0 .. 63: Servo 5 End position "B" Mode : Digital   Proportional
16	<b>SERVO 5 SPEED</b> Speed A : 40 Speed B : 40 SPE REL : Delay On	Speed A : 0 .. 63: Adjustment speed on the way to "A" Speed B : 0 .. 63: Adjustment speed on the way to "B" SPE REL : Delay On   Delay Off

## Menu references SwitchPilot 3 Servo

No	Screen	Options
17	<b>SERVO 5 BOUNCING</b> Bouncing: Pos A+B Bounces : 0 Strength: 0	Bouncing: Disabled   Pos A   Pos B   Pos A+B Bounces : 0 .. 31 Strength: 0 .. 31
18	<b>SERVO 6 POSITION</b> Pos A : 24 Pos B : 40 Mode : Digital	Pos A : 0 .. 63: Servo 6 End position "A" Pos B : 0 .. 63: Servo 6 End position "B" Mode : Digital   Proportional
19	<b>SERVO 6 SPEED</b> Speed A : 40 Speed B : 40 SPE REL : Delay On	Speed A : 0 .. 63: Adjustment speed on the way to "A" Speed B : 0 .. 63: Adjustment speed on the way to "B" SPE REL : Delay On   Delay Off
20	<b>SERVO 6 BOUNCING</b> Bouncing: Pos A+B Bounces : 0 Strength: 0	Bouncing: Disabled   Pos A   Pos B   Pos A+B Bounces : 0 .. 31 Strength: 0 .. 31
21	<b>SERVO 7 POSITION</b> Pos A : 24 Pos B : 40 Mode : Digital	Pos A : 0 .. 63: Servo 7 End position "A" Pos B : 0 .. 63: Servo 7 End position "B" Mode : Digital   Proportional
22	<b>SERVO 7 SPEED</b> Speed A : 40 Speed B : 40 SPE REL : Delay On	Speed A : 0 .. 63: Adjustment speed on the way to "A" Speed B : 0 .. 63: Adjustment speed on the way to "B" SPE REL : Delay On   Delay Off
23	<b>SERVO 7 BOUNCING</b> Bouncing: Pos A+B Bounces : 0 Strength: 0	Bouncing: Disabled   Pos A   Pos B   Pos A+B Bounces : 0 .. 31 Strength: 0 .. 31
24	<b>SERVO 8 POSITION</b> Pos A : 24 Pos B : 40 Mode : Digital	Pos A : 0 .. 63: Servo 8 End position "A" Pos B : 0 .. 63: Servo 8 End position "B" Mode : Digital   Proportional

## Menu references SwitchPilot 3 Servo

No	Screen	Options
25	<pre>SERVO 8 SPEED Speed A : 40 Speed B : 40 SPE REL : Delay On</pre>	<pre>Speed A : 0 .. 63: Adjustment speed on the way to "A" Speed B : 0 .. 63: Adjustment speed on the way to "B" SPE REL : Delay On   Delay Off</pre>
26	<pre>SERVO 8 BOUNCING Bouncing: Pos A+B Bounces : 0 Strength: 0</pre>	<pre>Bouncing: Disabled   Pos A   Pos B   Pos A+B Bounces : 0 .. 31 Strength: 0 .. 31</pre>
27	<pre>FUNCTION MAPPING F1 Servo   : »»»»»»»»           1234 5678</pre>	Servo: Which servo should be switched with turnout number 1
28	<pre>FUNCTION MAPPING F2 Servo   : »»»»»»»»           1234 5678</pre>	Servo: Which servo should be switched with turnout number 2
29	<pre>FUNCTION MAPPING F3 Servo   : »»»»»»»»           1234 5678</pre>	Servo: Which servo should be switched with turnout number 3
30	<pre>FUNCTION MAPPING F4 Servo   : »»»»»»»»           1234 5678</pre>	Servo: Which servo should be switched with turnout number 4
31	<pre>FUNCTION MAPPING F5 Servo   : »»»»»»»»           1234 5678</pre>	Servo: Which servo should be switched with turnout number 5
32	<pre>FUNCTION MAPPING F6 Servo   : »»»»»»»»           1234 5678</pre>	Servo: Which servo should be switched with turnout number 6

## Menu references SwitchPilot 3 Servo

No	Screen	Options
33	<pre> <b>FUNCTION MAPPING F7</b> Servo : 1234 5678           </pre>	Servo: Which servo should be switched with turnout number 7
34	<pre> <b>FUNCTION MAPPING F8</b> Servo : 1234 5678           </pre>	Servo: Which servo should be switched with turnout number 8
35	<pre> <b>SERVO CONTROL</b> Imp On : Always Imp Off : Never PWR : Always           </pre>	Imp On : Always   On CMD Imp Off: Never   Timeout PWR : Always   On Move
36	<pre> <b>RAILCOM</b> Mode : Enabled CH2 : Enabled           </pre>	Mode: Enabled   Disabled CH2 : Enabled   Disabled
37	<pre> <b>RESET DECODER</b> Do Reset: No           </pre>	Do Reset: No   Yes
38	<pre> <b>INFORMATION</b> HW : 3.0 SW : 3.0.9 Voltage : 18.4V           </pre>	HW: Hardware version of the decoder. SW: Software version of the decoder. Update with LokProgrammer Voltage: Supply voltage of the decoder (if necessary rail tension)
39	<pre> <b>OUTPUT STATE</b> 1 2 3 4 5 6 7 8 CMD . » . » » . » . » . » » . END . » . » . » . » . » .           </pre>	

# Solenoid address & turnout numbers

## 16. Solenoid address & turnout numbers

CV 1, CV 9 follow RCN-213

Turnout numbers				Address	CV1	CV 9
1	2	3	4	1	1	0
5	6	7	8	2	2	0
9	10	11	12	3	3	0
13	14	15	16	4	4	0
17	18	19	20	5	5	0
21	22	23	24	6	6	0
25	26	27	28	7	7	0
29	30	31	32	8	8	0
33	34	35	36	9	9	0
37	38	39	40	10	10	0
41	42	43	44	11	11	0
45	46	47	48	12	12	0
49	50	51	52	13	13	0
53	54	55	56	14	14	0
57	58	59	60	15	15	0
61	62	63	64	16	16	0
65	66	67	68	17	17	0
69	70	71	72	18	18	0
73	74	75	76	19	19	0
77	78	79	80	20	20	0
81	82	83	84	21	21	0
85	86	87	88	22	22	0
89	90	91	92	23	23	0
93	94	95	96	24	24	0
97	98	99	100	25	25	0
101	102	103	104	26	26	0
105	106	107	108	27	27	0
109	110	111	112	28	28	0
113	114	115	116	29	29	0
117	118	119	120	30	30	0
121	122	123	124	31	31	0
125	126	127	128	32	32	0
129	130	131	132	33	33	0
133	134	135	136	34	34	0

Turnout numbers				Address	CV1	CV 9
137	138	139	140	35	35	0
141	142	143	144	36	36	0
145	146	147	148	37	37	0
149	150	151	152	38	38	0
153	154	155	156	39	39	0
157	158	159	160	40	40	0
161	162	163	164	41	41	0
165	166	167	168	42	42	0
169	170	171	172	43	43	0
173	174	175	176	44	44	0
177	178	179	180	45	45	0
181	182	183	184	46	46	0
185	186	187	188	47	47	0
189	190	191	192	48	48	0
193	194	195	196	49	49	0
197	198	199	200	50	50	0
201	202	203	204	51	51	0
205	206	207	208	52	52	0
209	210	211	212	53	53	0
213	214	215	216	54	54	0
217	218	219	220	55	55	0
221	222	223	224	56	56	0
225	226	227	228	57	57	0
229	230	231	232	58	58	0
233	234	235	236	59	59	0
237	238	239	240	60	60	0
241	242	243	244	61	61	0
245	246	247	248	62	62	0
249	250	251	252	63	63	0
253	254	255	256	64	0	1
257	258	259	260	65	1	1
261	262	263	264	66	2	1
265	266	267	268	67	3	1
269	270	271	272	68	4	1
273	274	275	276	69	5	1
277	278	279	280	70	6	1
281	282	283	284	71	7	1

# Solenoid address & turnout numbers

Turnout numbers				Address	CV1	CV 9
285	286	287	288	72	8	1
289	290	291	292	73	9	1
293	294	295	296	74	10	1
297	298	299	300	75	11	1
301	302	303	304	76	12	1
305	306	307	308	77	13	1
309	310	311	312	78	14	1
313	314	315	316	79	15	1
317	318	319	320	80	16	1
321	322	323	324	81	17	1
325	326	327	328	82	18	1
329	330	331	332	83	19	1
333	334	335	336	84	20	1
337	338	339	340	85	21	1
341	342	343	344	86	22	1
345	346	347	348	87	23	1
349	350	351	352	88	24	1
353	354	355	356	89	25	1
357	358	359	360	90	26	1
361	362	363	364	91	27	1
365	366	367	368	92	28	1
369	370	371	372	93	29	1
373	374	375	376	94	30	1
377	378	379	380	95	31	1
381	382	383	384	96	32	1
385	386	387	388	97	33	1
389	390	391	392	98	34	1
393	394	395	396	99	35	1
397	398	399	400	100	36	1
401	402	403	404	101	37	1
405	406	407	408	102	38	1
409	410	411	412	103	39	1
413	414	415	416	104	40	1
417	418	419	420	105	41	1
421	422	423	424	106	42	1
425	426	427	428	107	43	1
429	430	431	432	108	44	1

Turnout numbers				Address	CV1	CV 9
433	434	435	436	109	45	1
437	438	439	440	110	46	1
441	442	443	444	111	47	1
445	446	447	448	112	48	1
449	450	451	452	113	49	1
453	454	455	456	114	50	1
457	458	459	460	115	51	1
461	462	463	464	116	52	1
465	466	467	468	117	53	1
469	470	471	472	118	54	1
473	474	475	476	119	55	1
477	478	479	480	120	56	1
481	482	483	484	121	57	1
485	486	487	488	122	58	1
489	490	491	492	123	59	1
493	494	495	496	124	60	1
497	498	499	500	125	61	1
501	502	503	504	126	62	1
505	506	507	508	127	63	1
509	510	511	512	128	0	2
513	514	515	516	129	1	2
517	518	519	520	130	2	2
521	522	523	524	131	3	2
525	526	527	528	132	4	2
529	530	531	532	133	5	2
533	534	535	536	134	6	2
537	538	539	540	135	7	2
541	542	543	544	136	8	2
545	546	547	548	137	9	2
549	550	551	552	138	10	2



# List of all supported CVs

CV	Name	Description	Range	Value	
1	Decoder address 1, LSB	Lower 6 bits (bit 0 - 5) of the first decoder address for outputs 1 to 4. Used together with CV 9 to save the address.	1 - 63	1	
7	Version number	Internal software version of the decoder		201	
8	Manufacturer ID	Manufacturer number (ID) of ESU. Writing the value 8 resets all CV to the factory setting.	-	151	
9	Decoder address 1, MSB	Upper 3 bits (bits 6 - 8) of the first decoder address for outputs 1 to 4. Used together with CV 1 to save the address.	0 - 7	0	
28	RailCom Configuration	Activation and configuration of the RailCom function	0,2	2	
		<b>Bit</b>	<b>Description</b>		<b>Value</b>
		1	Data transmission on channel 2 No data transmission on channel 2 Data transmission allowed on channel 2		0 2
29	Configuration register	DCC configuration settings for the SwitchPilot	128,136	128	
		<b>Bit</b>	<b>Description</b>		<b>Value</b>
		3	RailCom communication RailCom communication is switched off RailCom communication allowed		0 8
		7	Decoder is DCC Accessory Decoder (solenoid) (read only, cannot be changed)		128
35	Decoder address 2, LSB	Lower 6 bits (bit 0 - 5) of the second decoder address for outputs 5 to 8. Used together with CV 36 to save the address.	1 - 63	2	
36	Decoder address 2, MSB	Upper 3 bits (bits 6 - 8) of the second decoder address for outputs 5 to 8. Used together with CV 36 to save the address.	0 - 7	0	
37	DCC turnout addressing	Calculation of the turnout numbers from the decoder address	0,1	0	
		<b>Bit</b>	<b>Description</b>		<b>Value</b>
		0	DCC turnout addressing compliant with RCN-213 DCC turnout addressing for ROCO centers		0 1

# List of all supported CVs

CV	Name	Description	Range	Value		
43	Pulse configuration	Options for generating the servo pulses. This applies equally to all outputs.	0 - 7	0		
		<b>Bit</b>			<b>Description</b>	<b>Value</b>
		0			Always generate a servo pulse	
					Generate servo impulse only after the first command	1
		1			Never switch off the servo pulse	
					Switch off the servo pulse approx. 1 second after reaching the end position	2
	2	Always supply power to the servo				
		Only supply the servo with power when it is to be moved	4			
44	Function Mapping „F1“	Servos that switch at turnout number 1.	0 - 255	1		
		<b>Bit</b>			<b>Description</b>	<b>Value</b>
		0			Servo 1	1
		1			Servo 2	2
		2			Servo 3	4
		3			Servo 4	8
		4			Servo 5	16
		5			Servo 6	32
		6			Servo 7	64
7	Servo 8	128				
45	Function Mapping „F2“	Servos that switch at turnout number 2.	0 - 255	2		
		<b>Bit</b>			<b>Description</b>	<b>Value</b>
46	Function Mapping „F3“	Servos that switch at turnout number 3.	0 - 255	4		
		<b>Bit</b>			<b>Description</b>	<b>Value</b>
47	Function Mapping „F4“	Servos that switch at turnout number 4.	0 - 255	8		
		<b>Bit</b>			<b>Description</b>	<b>Value</b>
48	Function Mapping „F5“	Servos that switch at turnout number 5.	0 - 255	16		
		<b>Bit</b>			<b>Description</b>	<b>Value</b>
		- as CV 44 -				

# List of all supported CVs

CV	Name	Description	Range	Value		
49	Function Mapping „F6“	Servos that switch at turnout number 6.	0 - 255	32		
		Bit			Description	Value
		- as CV 44 -				
50	Function Mapping „F7“	Servos that switch at turnout number 7.	0 - 255	64		
		Bit			Description	Value
		- as CV 44 -				
51	Function Mapping „F8“	Servos that switch at turnout number 8.	0 - 255	128		
		Bit			Description	Value
		- as CV 44 -				
112	Servo 1 speed A	Running time (speed of rotation) towards end position „A“. Running time is a multiple of 0.25 seconds: 1 = 0.25s, 63 = 15.75s	0 - 63	15		
113	Servo 1 End position A	End position A of servo 1st value indicates the pulse length that is sent to the servo.	0 - 63	24		
114	Servo 1 End position B	End position B of servo 1st value indicates the pulse length that is sent to the servo.	0 - 63	40		
115	Servo 1 speed B	Running time (speed of rotation) towards end position „B“. Running time is a multiple of 0.25 seconds: 1 = 0.25s, 63 = 15.75s	0 - 63	15		
116	Servo 1 number of bounces	Number of bounces, if bouncing is active	0 - 31	0		
117	Servo 1 Strength bouncing	Strength of the bouncing, if bouncing is active	0 - 31	0		
118	Servo 1 Options	Settings for servo 1	128,136	128		
		Bit	Description	Value		
		0	Rocking switched off when position „A“ is reached Rocking switched on when position „A“ is reached	1		
		1	Rocking switched off when position „B“ is reached Rocking switched on when position „B“ is reached	2		
		2	Operating mode: digital mode (servo always stops at „A“ or „B“) Operating mode: Proportional mode (servo runs as long as the button is pressed)	4		
		3	SwitchPilot Extension: The assigned relay is switched immediately SwitchPilot Extension: The assigned relay is switched with a delay	8		

# List of all supported CVs

CV	Name	Description	Range	Value
120	Servo 2 Speed A	- as CV 112 -	0 - 63	15
121	Servo 2, Pos A	- as CV 113 -	0 - 63	24
122	Servo 2, Pos B	- as CV 114 -	0 - 63	40
123	Servo 2 , Speed B	- as CV 115 -	0 - 63	15
124	Servo 2, #Bounces	- as CV 116 -	0 - 31	0
125	Servo 2, Strength	- as CV 117 -	0 - 31	0
126	Servo 2, Optionen	- as CV 118 -	0 - 31	0
128	Servo 3 Speed A	- as CV 112 -	0 - 63	15
129	Servo 3, Pos A	- as CV 113 -	0 - 63	24
130	Servo 3, Pos B	- as CV 114 -	0 - 63	40
131	Servo 3 , Speed B	- as CV 115 -	0 - 63	15
132	Servo 3, #Bounces	- as CV 116 -	0 - 31	0
133	Servo 3, Strength	- as CV 117 -	0 - 31	0
134	Servo 3, Optionen	- as CV 118 -	0 - 31	0
136	Servo 4 Speed A	- as CV 112 -	0 - 63	15
137	Servo 4, Pos A	- as CV 113 -	0 - 63	24
138	Servo 4, Pos B	- as CV 114 -	0 - 63	40
139	Servo 4 , Speed B	- as CV 115 -	0 - 63	15
140	Servo 4, #Bounces	- as CV 116 -	0 - 31	0
141	Servo 4, Strength	- as CV 117 -	0 - 31	0
142	Servo 4, Optionen	- as CV 118 -	0 - 31	0
144	Servo 5, Speed A	- as CV 112 -	0 - 63	15
145	Servo 5, Pos A	- as CV 113 -	0 - 63	24
146	Servo 5, Pos B	- as CV 114 -	0 - 63	40
147	Servo 5 , Speed B	- as CV 115 -	0 - 63	15
148	Servo 5, #Bounces	- as CV 116 -	0 - 31	0
149	Servo 5, Strength	- as CV 117 -	0 - 31	0
150	Servo 5, Optionen	- as CV 118 -	0 - 31	0

## List of all supported CVs

CV	Name	Description	Range	Value
152	Servo 6, Speed A	- as CV 112 -	0 - 63	15
153	Servo 6, Pos A	- as CV 113 -	0 - 63	24
154	Servo 6, Pos B	- as CV 114 -	0 - 63	40
155	Servo 6, Speed B	- as CV 115 -	0 - 63	15
156	Servo 6, #Bounces	- as CV 116 -	0 - 31	0
157	Servo 6, Strength	- as CV 117 -	0 - 31	0
158	Servo 6, Optionen	- as CV 118 -	0 - 31	0
160	Servo 7, Speed A	- as CV 112 -	0 - 63	15
161	Servo 7, Pos A	- as CV 113 -	0 - 63	24
162	Servo 7, Pos B	- as CV 114 -	0 - 63	40
163	Servo 7, Speed B	- as CV 115 -	0 - 63	15
164	Servo 7, #Bounces	- as CV 116 -	0 - 31	0
165	Servo 7, Strength	- as CV 117 -	0 - 31	0
166	Servo 7, Optionen	- as CV 118 -	0 - 31	0
168	Servo 8, Speed A	- as CV 112 -	0 - 63	15
169	Servo 8, Pos A	- as CV 113 -	0 - 63	24
170	Servo 8, Pos B	- as CV 114 -	0 - 63	40
171	Servo 8, Speed B	- as CV 115 -	0 - 63	15
172	Servo 8, #Bounces	- as CV 116 -	0 - 31	0
173	Servo 8, Strength	- as CV 117 -	0 - 31	0
174	Servo 8, Optionen	- as CV 118 -	0 - 31	0

## 18. Change history

---

### 2. EDITION MARCH 2021

- Spelling mistake corrected

### 1. EDITION DECEMBER 2020

- Initial Document

## 19. Warranty certificate

Dear customer,

Congratulations on purchasing this ESU ECoS command station. This quality product was manufactured applying the most advanced production methods and processes and was subject to stringent quality checks and tests.

Therefore ESU electronic solutions ulm GmbH & Co. KG grants you a warranty for the purchase of ESU products that far exceeds the national warranty as governed by legislation in your country and beyond the warranty from your authorised ESU dealer.

### **Manufacturer's warranty of 24 months from date of purchase.**

#### **Warranty conditions:**

This warranty is valid for all ESU products that have been purchased from an authorised ESU dealer.

Any service, repair or replacement under this warranty requires proof of purchase. The filled in warranty certificate together with the receipt from your ESU dealer serves as proof of purchase. We recommend keeping the warranty certificate together with the receipt.

In case of a claim please fill in the enclosed failure report card as detailed and precise as possible and return it with your faulty product.

Please use the appropriate postage when shipping to ESU.

#### **Extend of warranty / exclusions:**

This warranty covers free of charge repair or replacement of the faulty part, provided the failure is demonstrably due to faulty design, manufacturing, material or transport. Any further claims are explicitly excluded.

The warranty expires:

- In case of wear and tear due to normal use.
- In case of conversions of ESU – products with parts not approved by the manufacturer.
- In case of modification of parts.
- In case of inappropriate use (different to the intended use as specified by the manufacturer).
- If the instructions as laid down in the user manual by ESU electronic solutions ulm GmbH & Co. KG were not adhered to.

There is no extension of the warranty period due to any repairs carried out by ESU or replacements.

You may submit your warranty claim either with your dealer or by shipping the product in question with the warranty certificate, the receipt of purchase and the fault description directly to ESU electronic solutions ulm GmbH & Co. KG at:

ESU GmbH & Co. KG  
- Guarantee Section -  
Edisonallee 29  
D-89231 Neu-Ulm

# Trouble shooting sheet

## 1. Personal data

(Please write in BLOCK LETTERS)

Name: ..... \_\_\_\_\_  
Street: ..... \_\_\_\_\_  
.....  
ZIP/City: ..... | | | | |  
Country: ..... \_\_\_\_\_  
Email: ..... \_\_\_\_\_  
Phone: ..... \_\_\_\_\_  
Date: ..... \_\_\_\_\_  
Signature: ..... \_\_\_\_\_

## 2. Error

Transistor outputs

Servo outputs

No Function

Short circuit

No function from the start

Programming on the Main

## 3. Error description

.....  
.....  
.....

## 4. Receipt

Please enclose your receipt / invoice. Otherwise no warranty possible!

## 5. Additional information:

.....  
.....  
.....  
.....  
.....

## 6. Your retailer:

.....  
.....  
.....  
.....  
.....

Retailer's stamp or address

